

# 1. Principal dimensions - VEX 150

## 1.1 Horizontal VEX

VEX150HL

The principal dimensions are indicated on the following drawing:

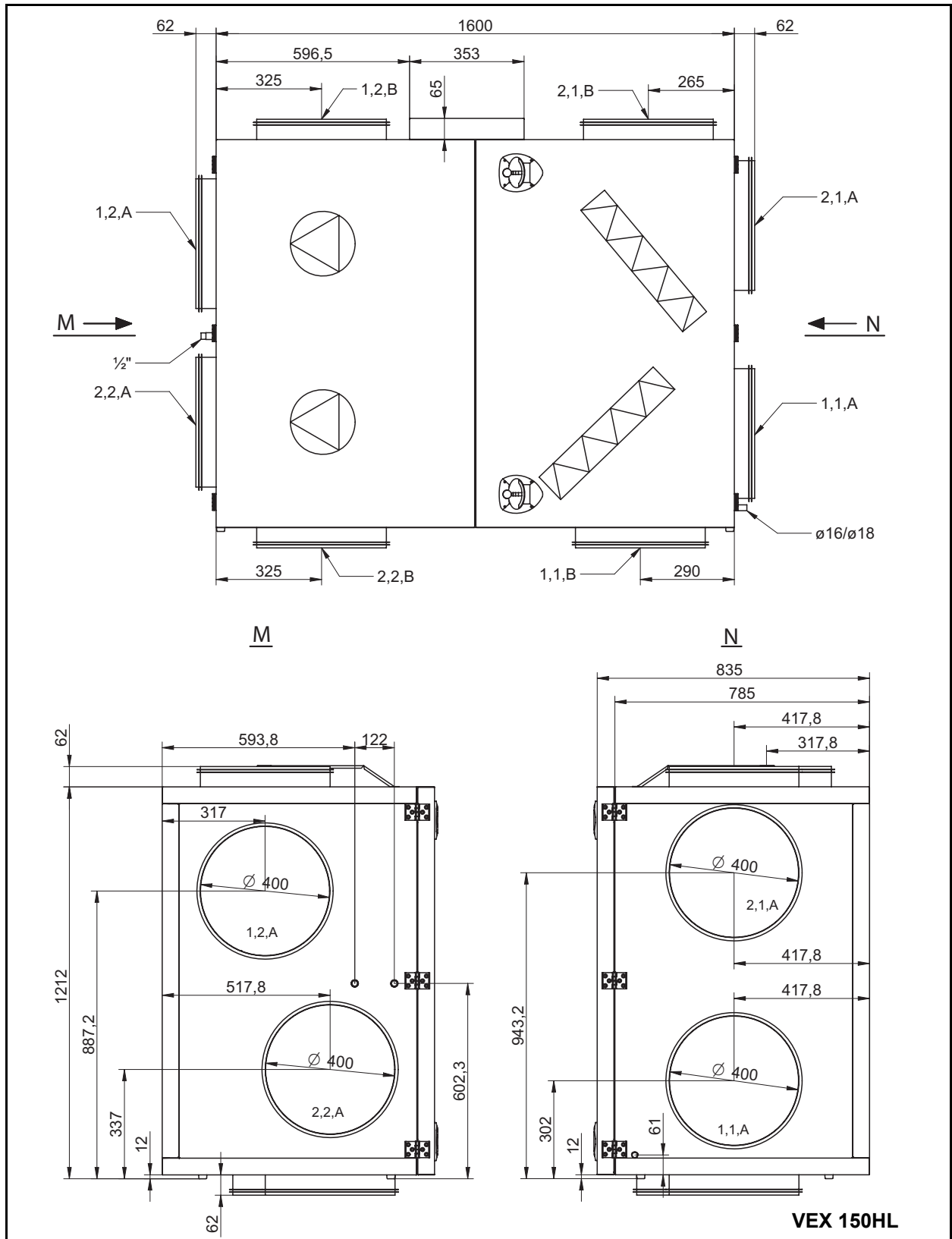

NB

The drawing shows all possible spigot locations.

**VEX150HR**

The principal dimensions are indicated on the following drawing:

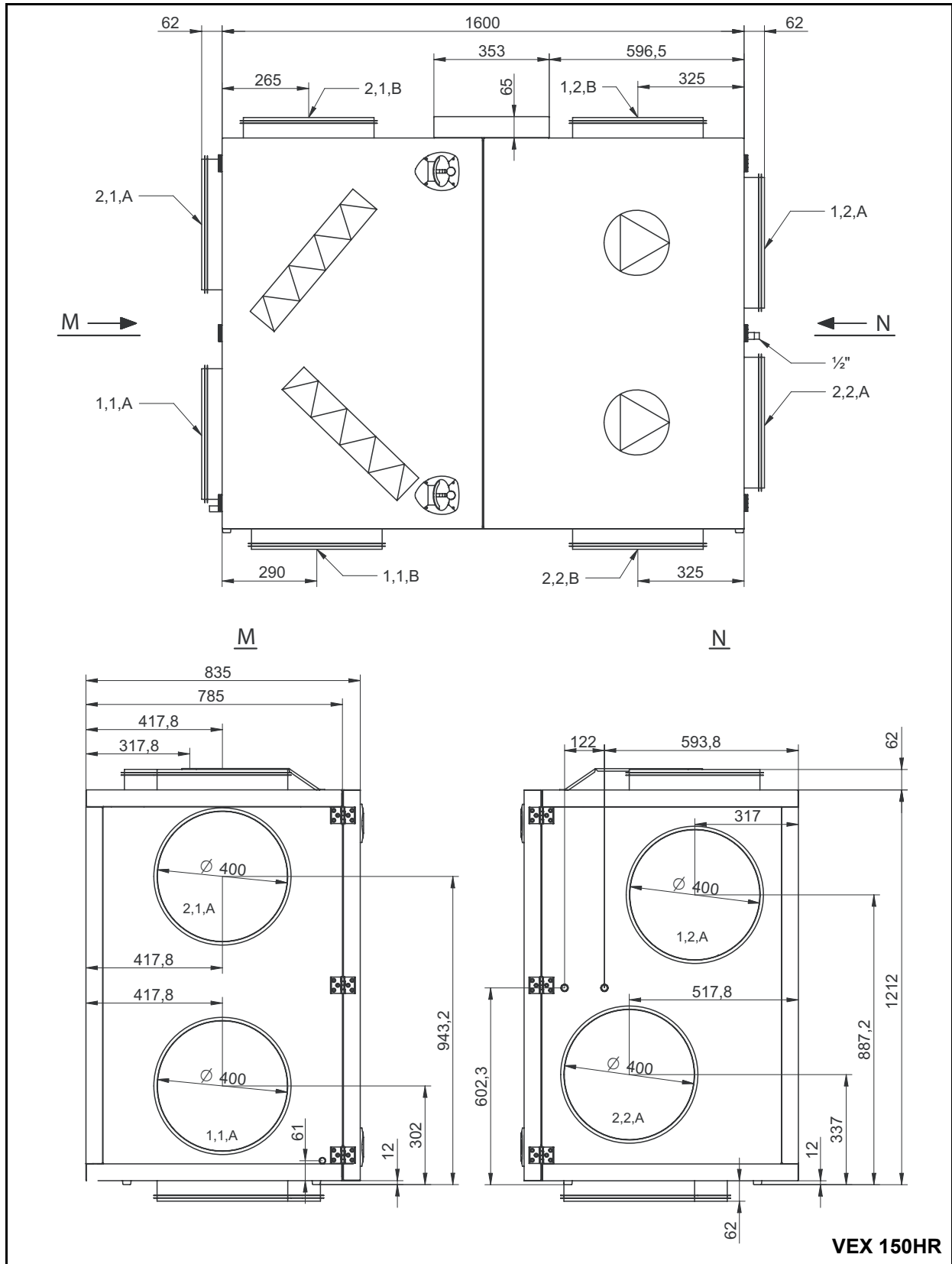

**NB**

The drawing shows all possible spigot locations.

## 1.2 Vertical VEX

VEX150VL

The principal dimensions are indicated on the following drawing:

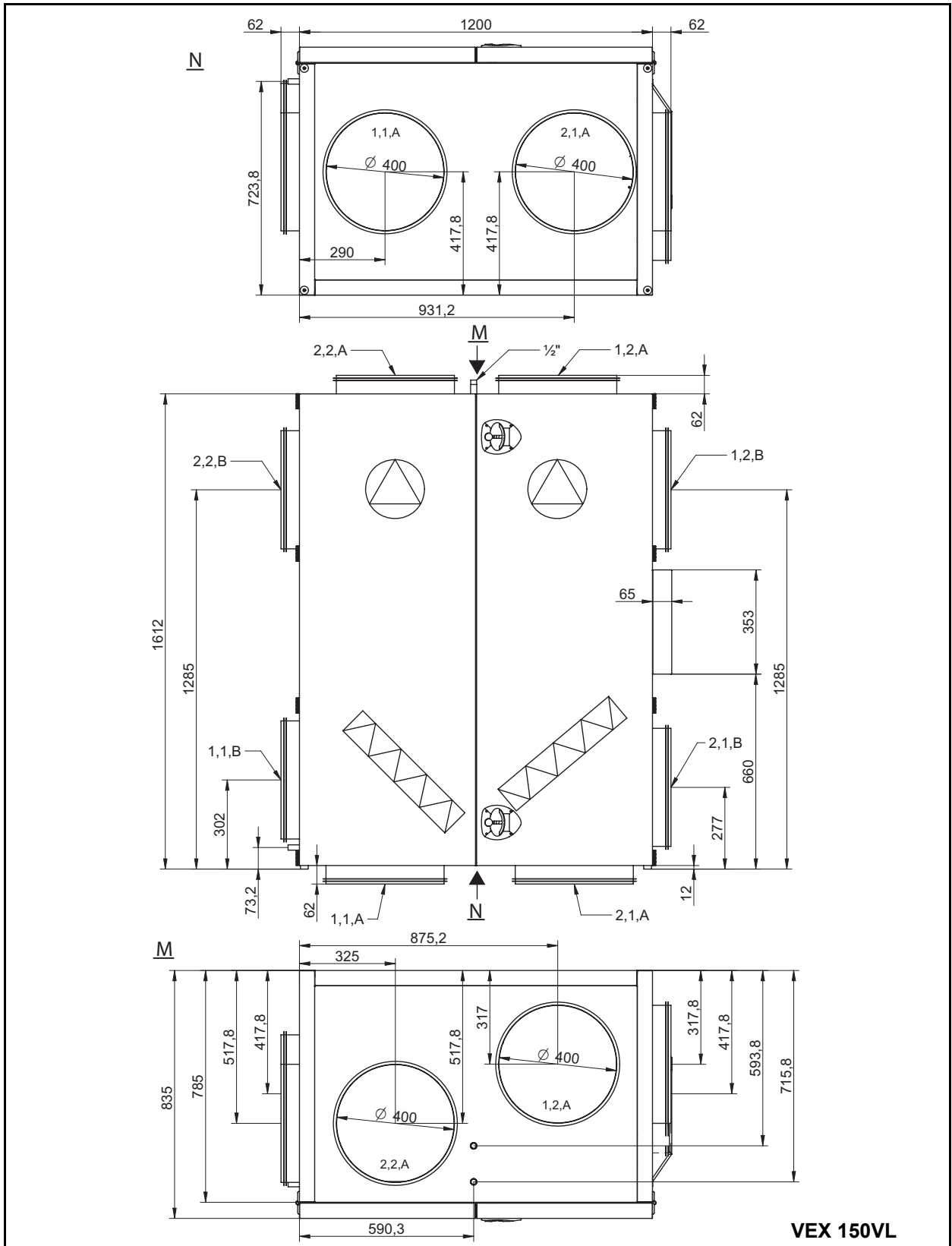

NB

The drawing shows all possible spigot locations.

**VEX150VR**

The principal dimensions are indicated on the following drawing:

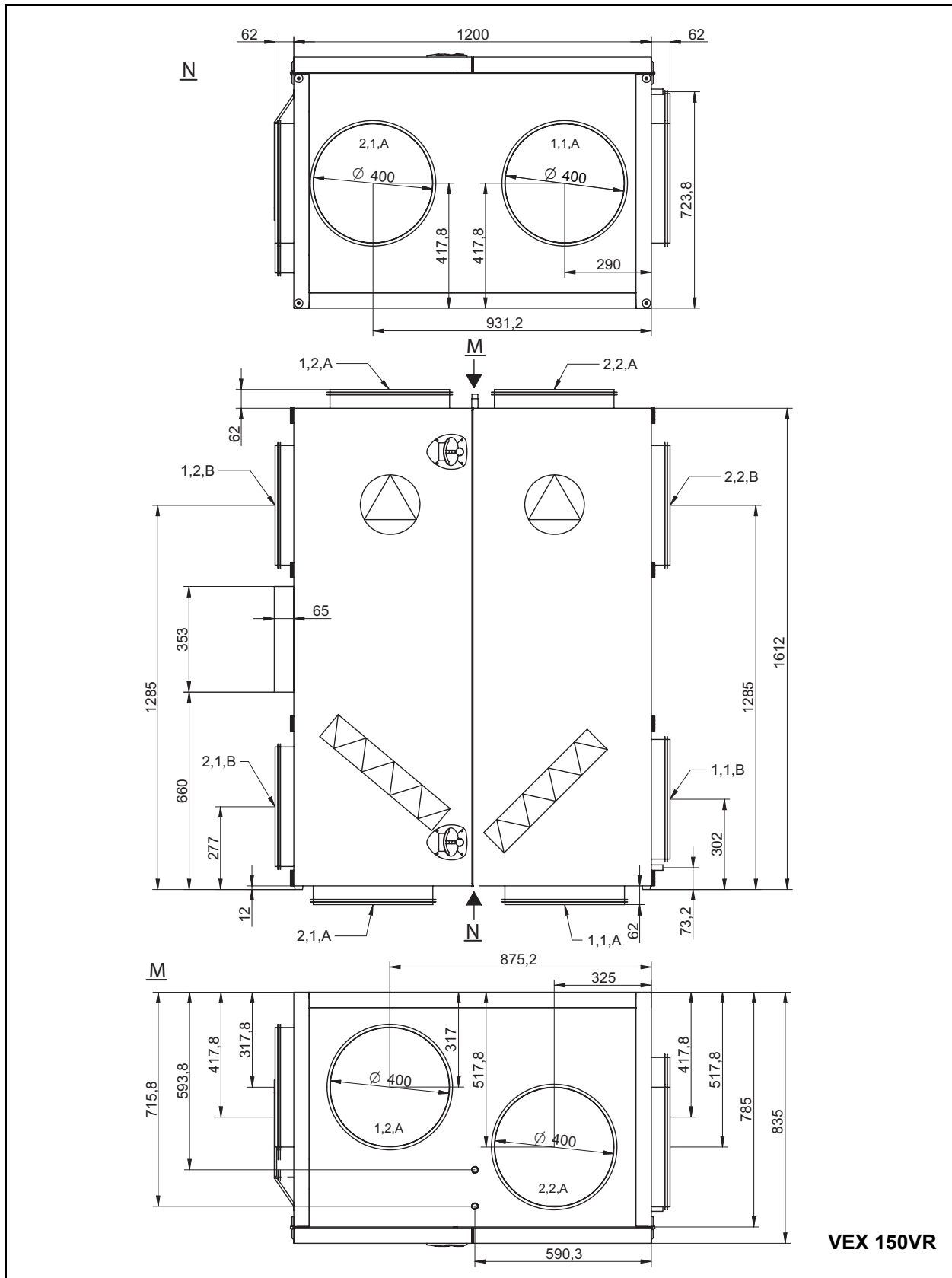

**VEX 150VR**

**NB**

The drawing shows all possible spigot locations.