

# 1. Principal dimensions - VEX 140

## 1.1 Horizontal VEX

VEX140HL

The principal dimensions are indicated on the following drawing:

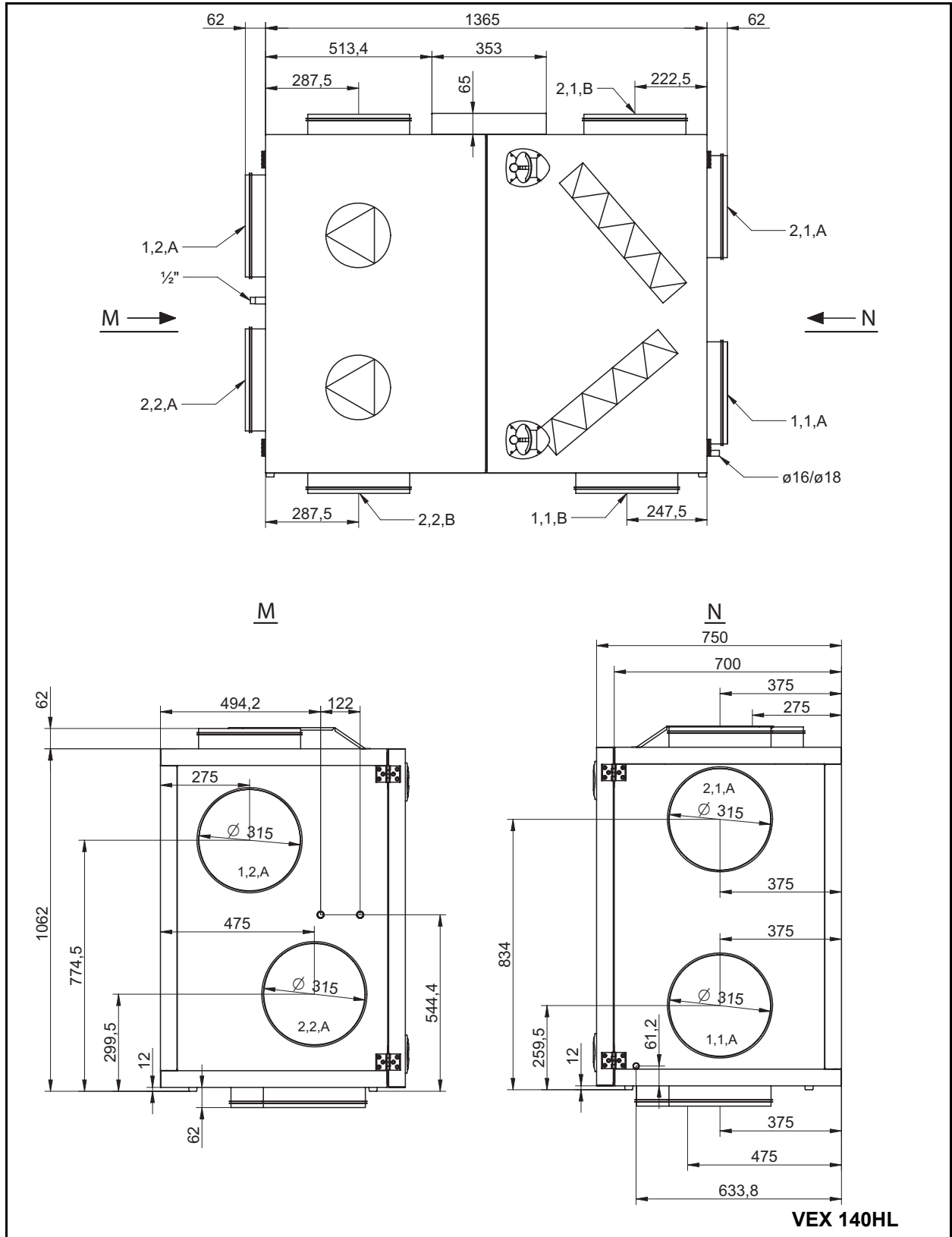

NB

The drawing shows all possible spigot locations.

**VEX140HR**

The principal dimensions are indicated on the following drawing:

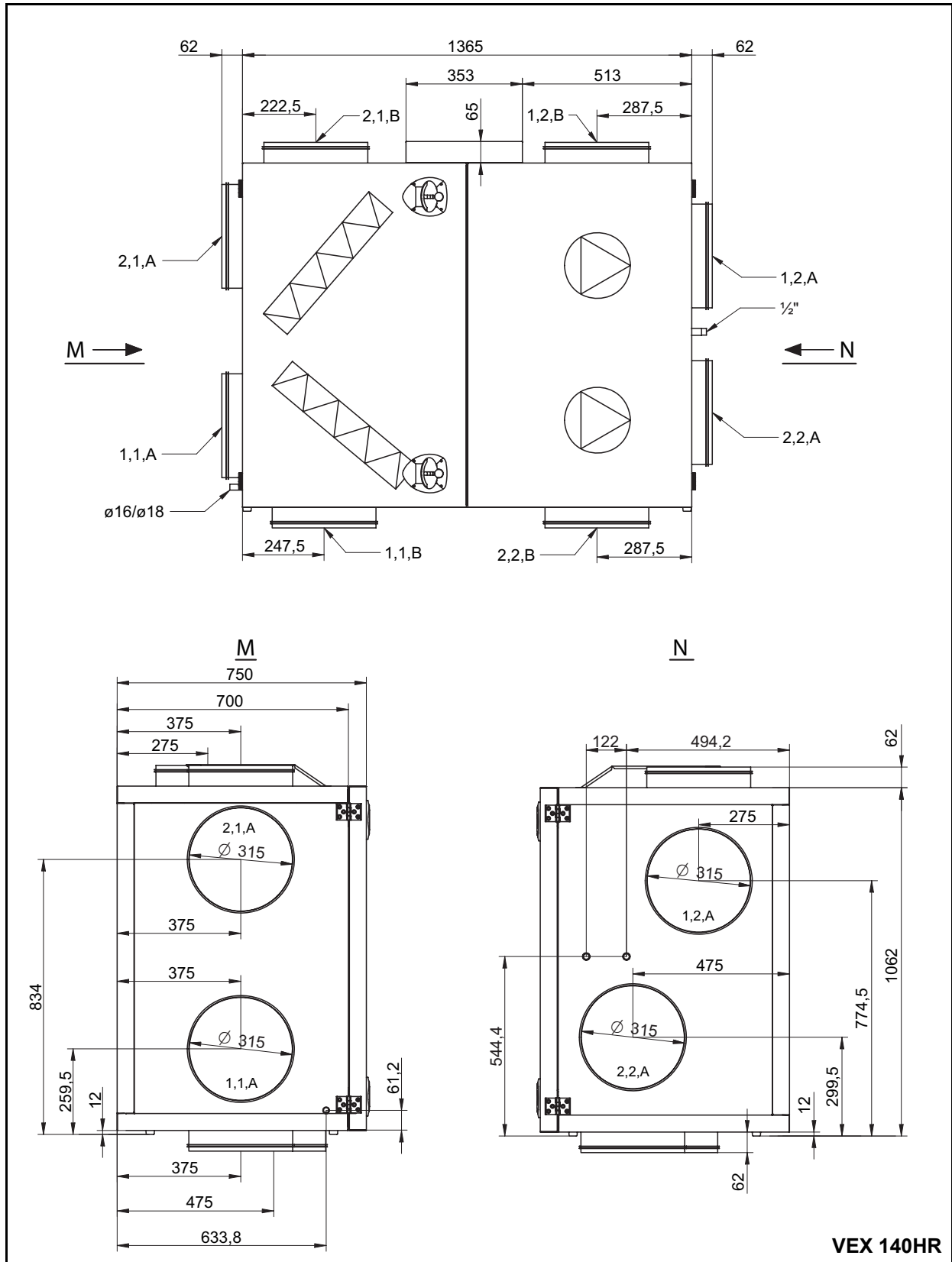

**VEX 140HR**

**NB**

The drawing shows all possible spigot locations.

## 1.2 VERTICAL VEX

VEX140VL

The principal dimensions are indicated on the following drawing:

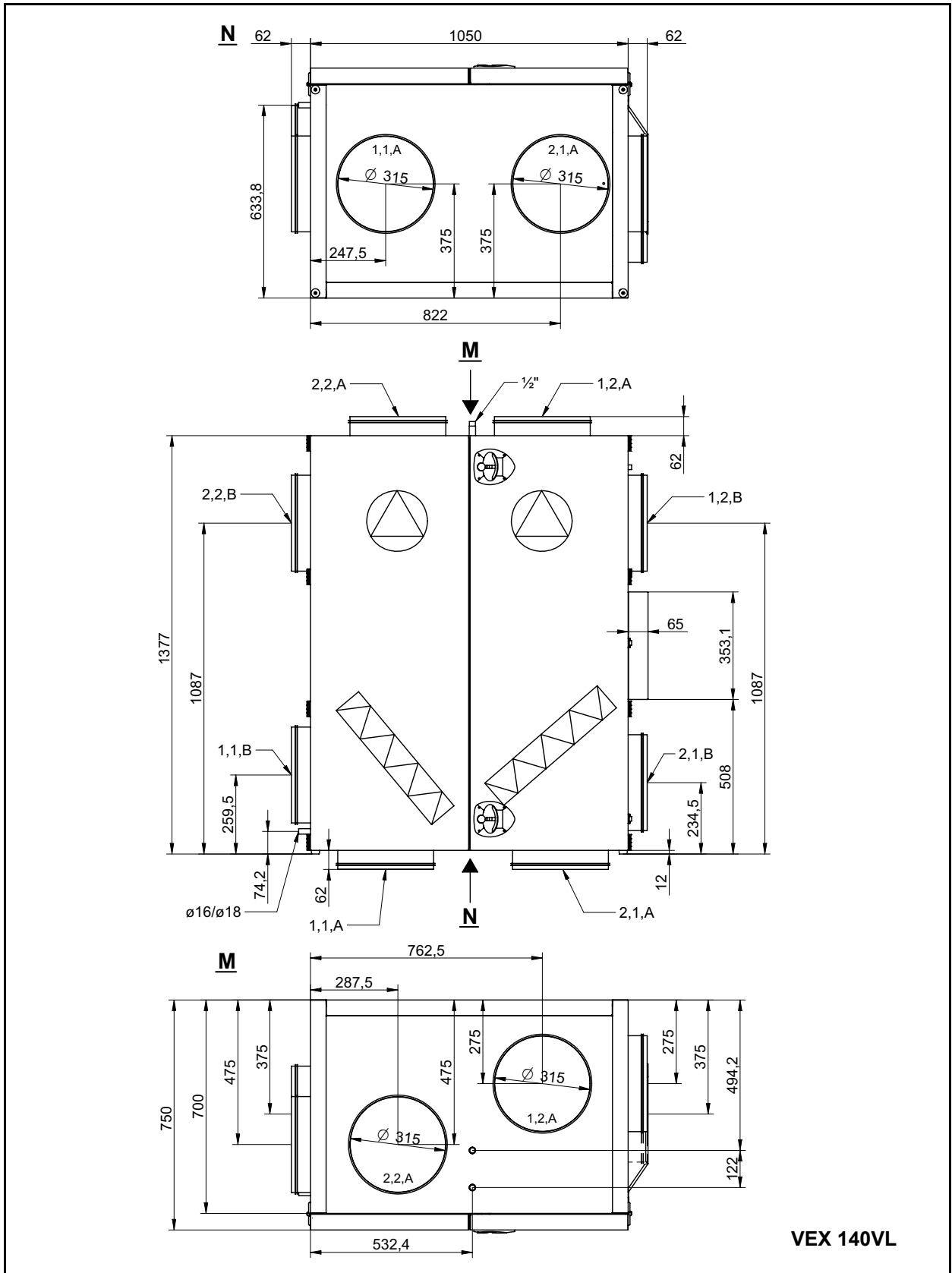

NB

The drawing shows all possible spigot locations.

VEX 140VL

**VEX140VR**

The principal dimensions are indicated on the following drawing:

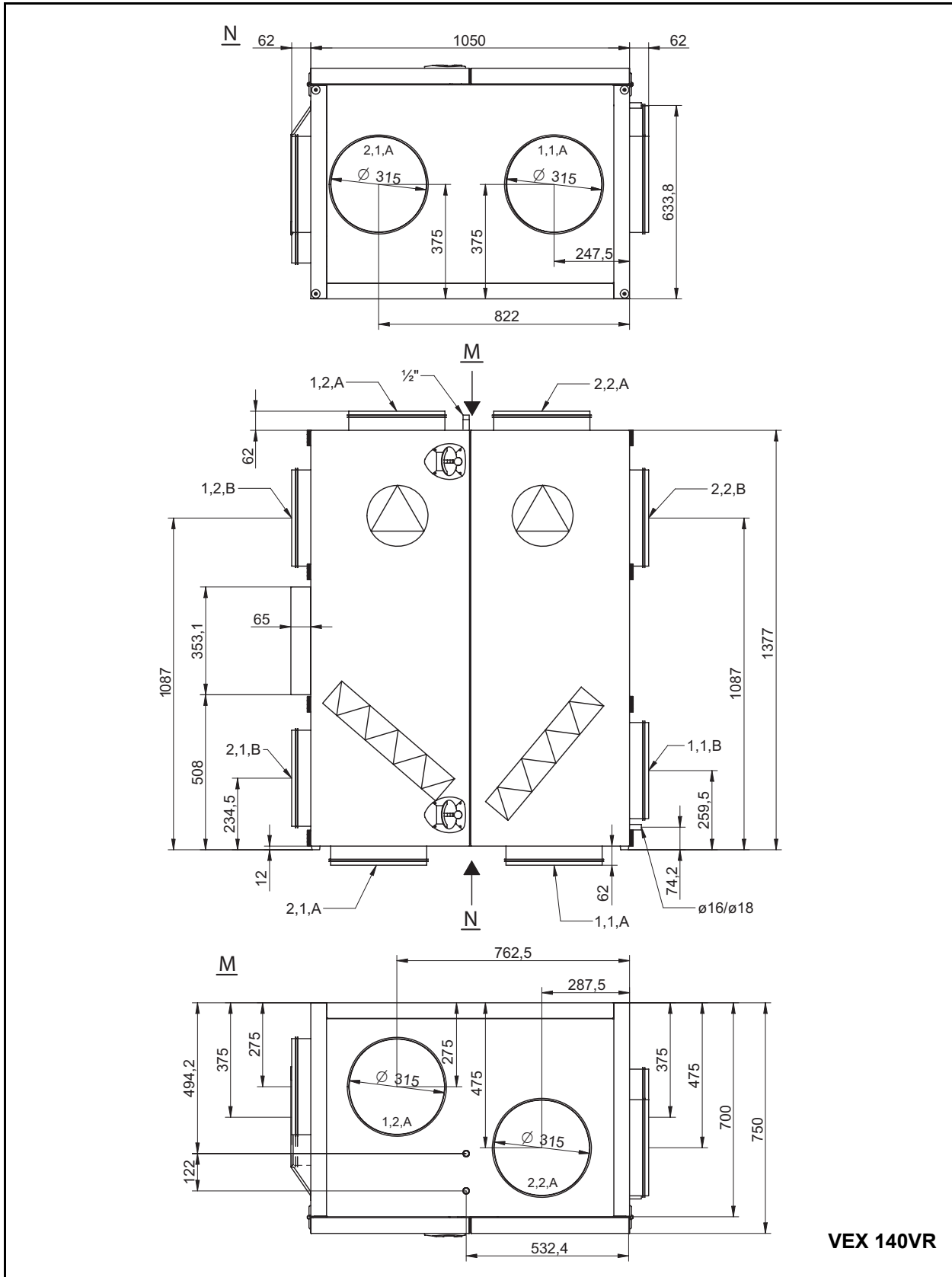

**VEX 140VR**

**NB**

The drawing shows all possible spigot locations.

### 1.3 CEILING VEX

VEX140CL

The principal dimensions are indicated on the following drawing:

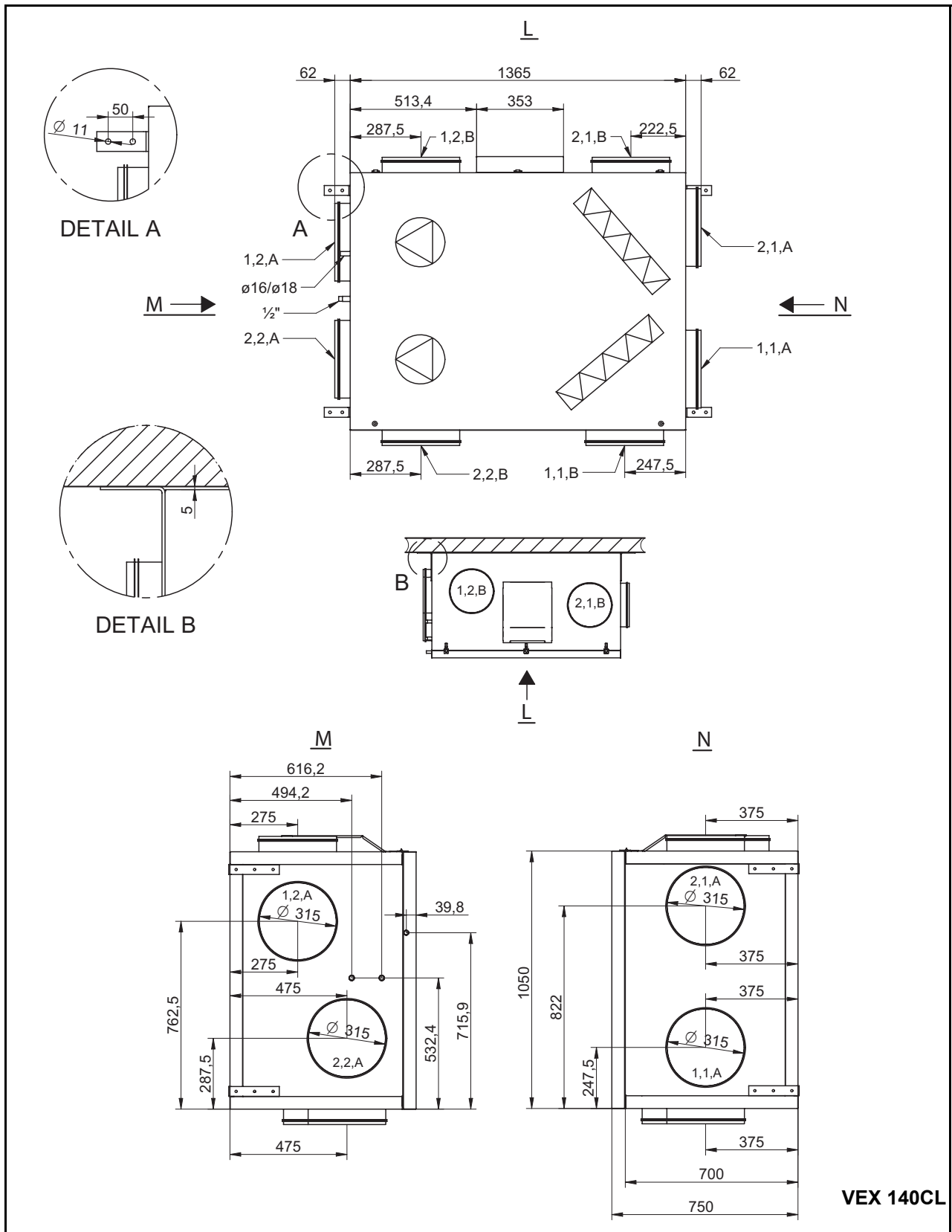

VEX 140CL

NB

The drawing shows all possible spigot locations.

**VEX140CR**

The principal dimensions are indicated on the following drawing:

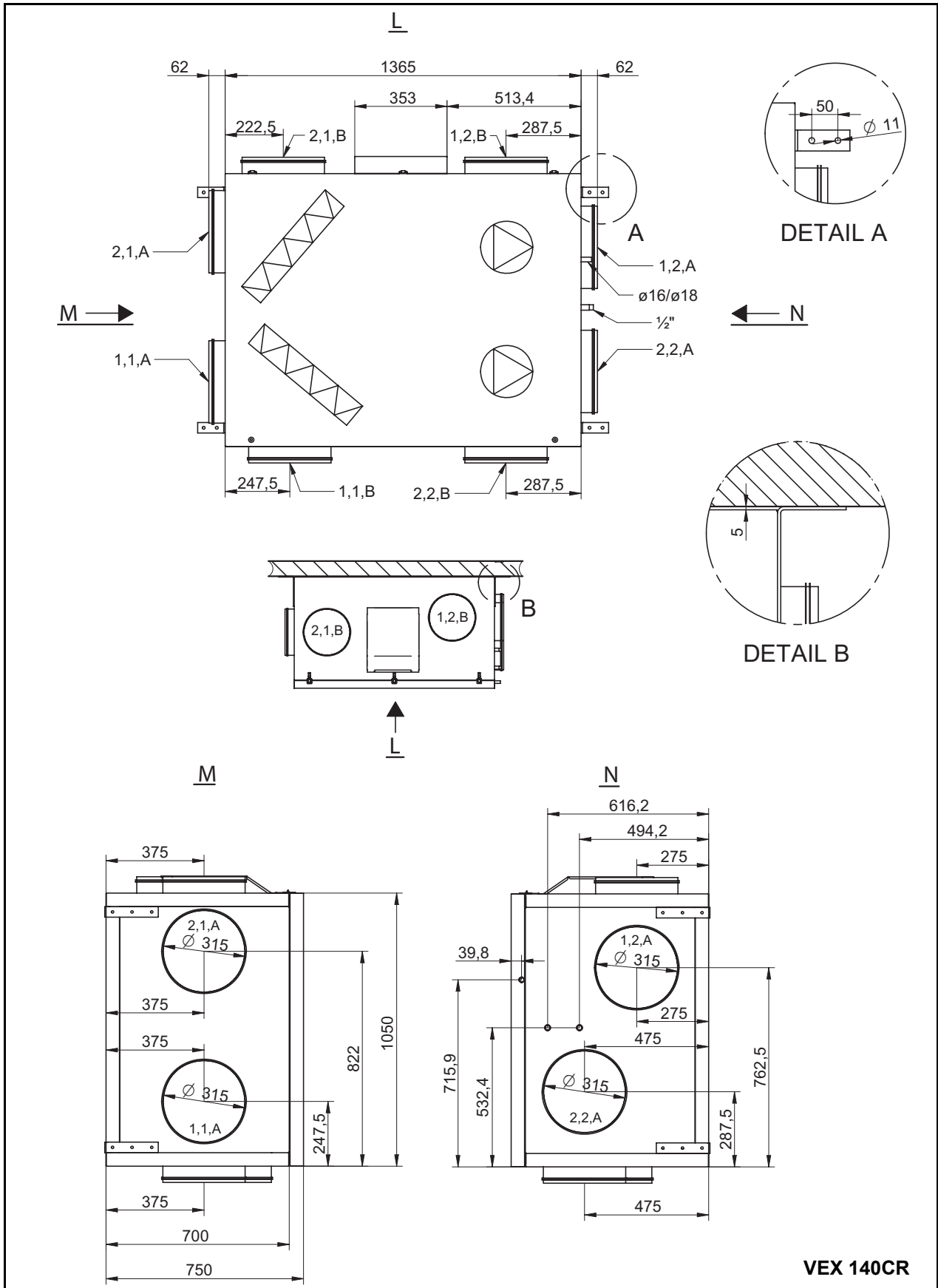

**NB**

The drawing shows all possible spigot locations.

**VEX 140CR**